



## PRODUCT INSTALLATION GUIDE

### WATERBRIDGE LAV - WALL MOUNT (WB LAV WM)





## PRODUCT INSTALLATION GUIDE

### WATERBRIDGE LAV - WALL MOUNT (WB LAV WM)

**CHECK LOCAL CODES FOR CLEARANCE REQUIRED  
BETWEEN BOTTOM OF SPOUT AND RIM OF VESSEL SINK**

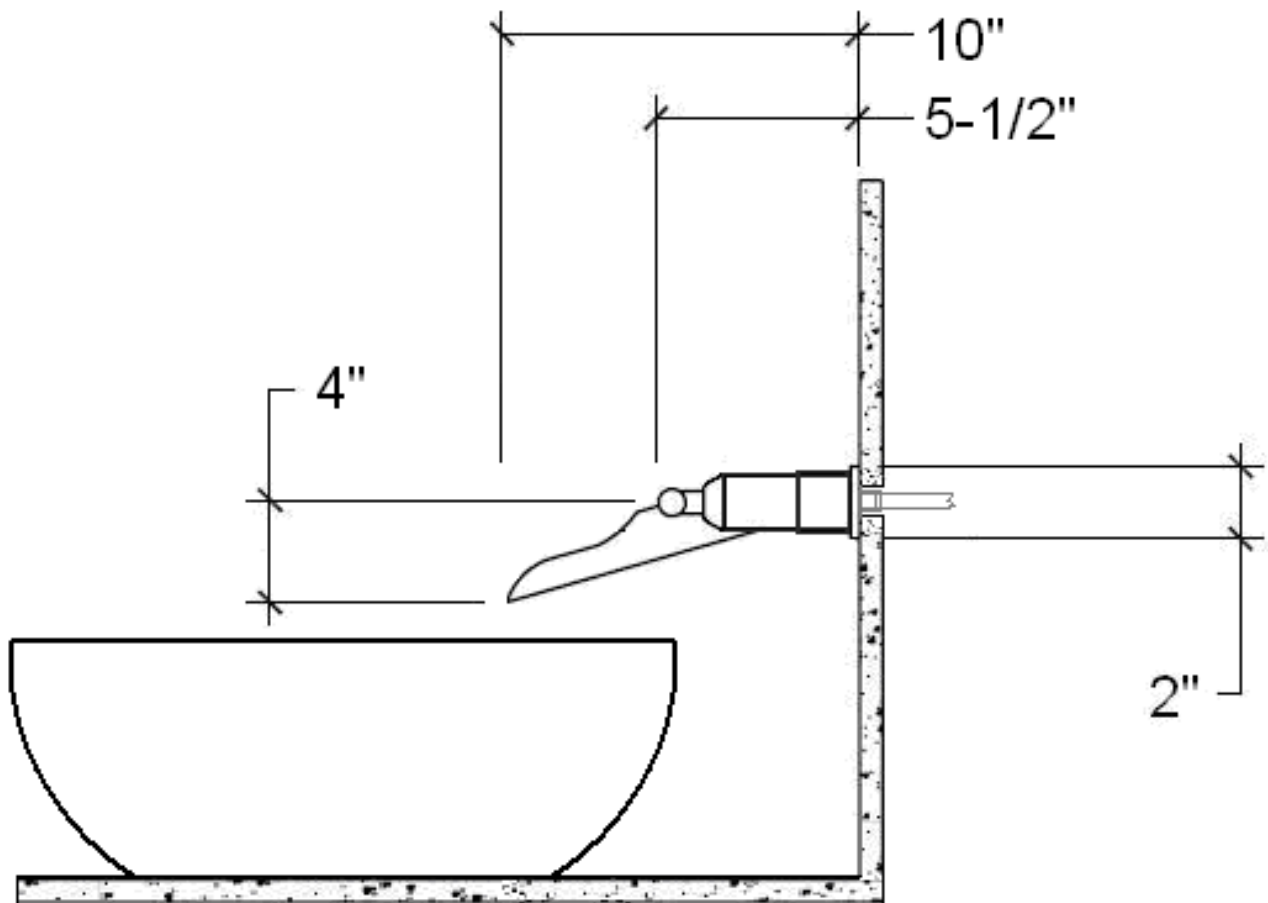



UPDATED  
VERSION  
JUN 2009

## PRODUCT INSTALLATION GUIDE

### WATERBRIDGE LAV - WALL MOUNT (WB LAV WM)

- 1) Using the picture on Page One of this guide for dimensions, determine the desired height for the faucet and mark the wall. Keep in mind the code for clearance between the spout and basin rim.
- 2) Install the **mounting template** (pictured below - included with the faucet) securely in the wall. Use a level to ensure the supply lines will be at the same height.

**NOTE:** Additional studs and/or framing in the wall behind the template may be required for added support. There must be at least 1/2" between the template and finished wall.

- 3) Run 1/2" supply lines through the mounting template. Leave enough stubbed-out beyond the finished wall to properly attach the faucet.
- 4) Solder the supply lines to the template for rigidity.
- 5) Cap the lines until ready to install trim.

#### MOUNTING TEMPLATE FOR EXPOSED SHOWERS AND/OR WALL FAUCETS:





UPDATED  
VERSION  
JUN 2009

## PRODUCT INSTALLATION GUIDE

### WATERBRIDGE LAV - WALL MOUNT TRIM

- 6) Carefully slide the sleeves toward the face of the faucet, exposing the compression nuts. Remove the nuts, being careful not to lose the ferrules. This faucet is shipped with temporary o-rings to keep the sleeves in place in transit. Remove these during installation.
- 7) Slide the trim rings, compression nuts, threaded sleeves, then the ferrules, in that order, over the copper lines from Step #3.

**NOTE: The threads on the 3/4" long sleeves serve no function in this application.**

**FAUCET, TRIM SLEEVE, FERRULE, THREADED SLEEVE, COMPRESSION NUT, TRIM RING, MOUNTING TEMPLATE:**



- 8) Supporting the faucet, tighten the compression nuts onto the back of the faucet. If the copper supply lines need to be trimmed, remove the faucet and return to step #7.

If you choose to use the optional flow restrictors included with your faucet, they should be installed now. These are placed flat into the body of the faucet before installed onto the supply lines.

- 9) Gently slide the sleeves back over the compression nuts and against the trim rings.
- 10) Water test for leaks.