

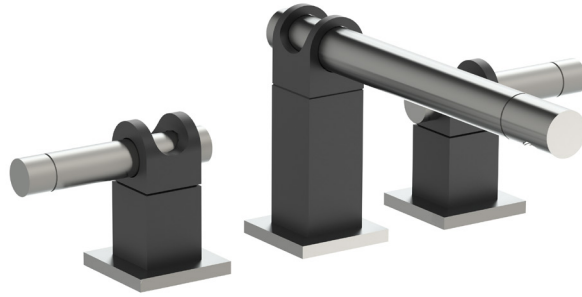

INSTALLATION DETAILS

Strap Deck Mounted Lavatory Faucet ST-LAV-DM

March 2015



Lavatory Spout Installation

1. Remove 3-Way Tee, Mounting Nut, Mounting Washer and Base Flange from the Mounting Shank as shown in **FIG 1**.
Note: Make sure not to remove the Teflon Washer from the 3-Way Tee or the O-ring from the Base Flange.
2. Insert spout assembly through 1-1/4" hole in deck with Base Flange in place, then install mounting hardware in order shown in **FIG 2**.
3. Tighten Mounting Hardware and 3-Way Tee underneath deck so Spout Assembly is secure and the 3-Way Tee is water tight.

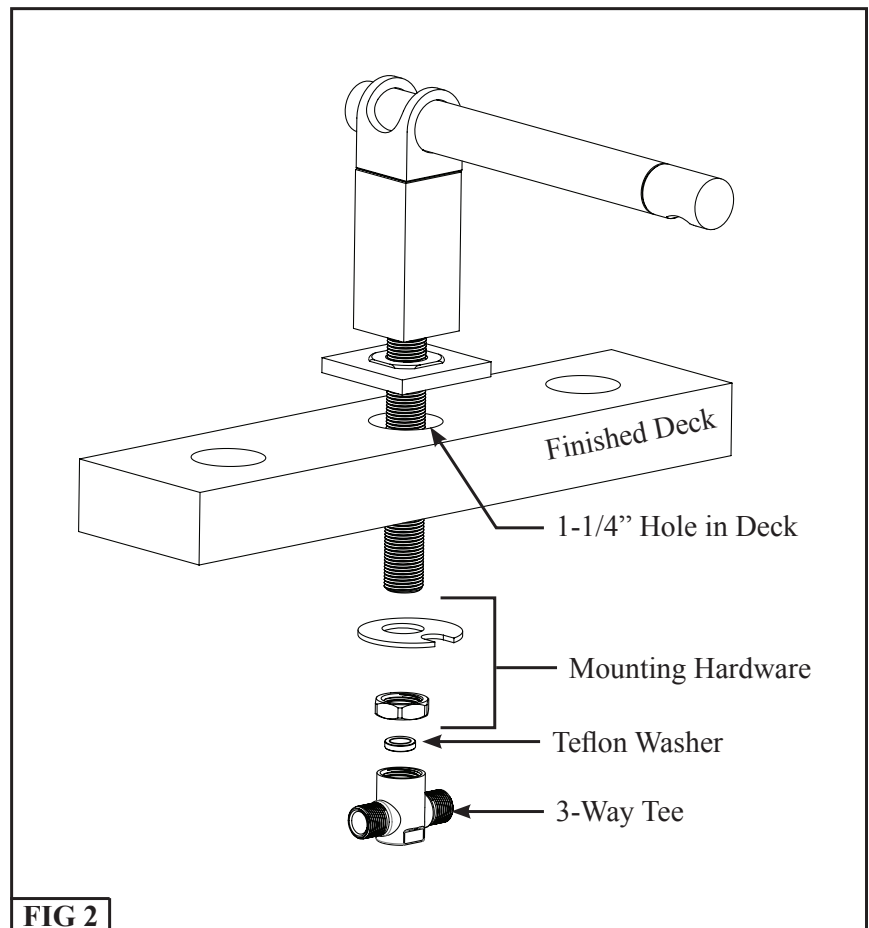
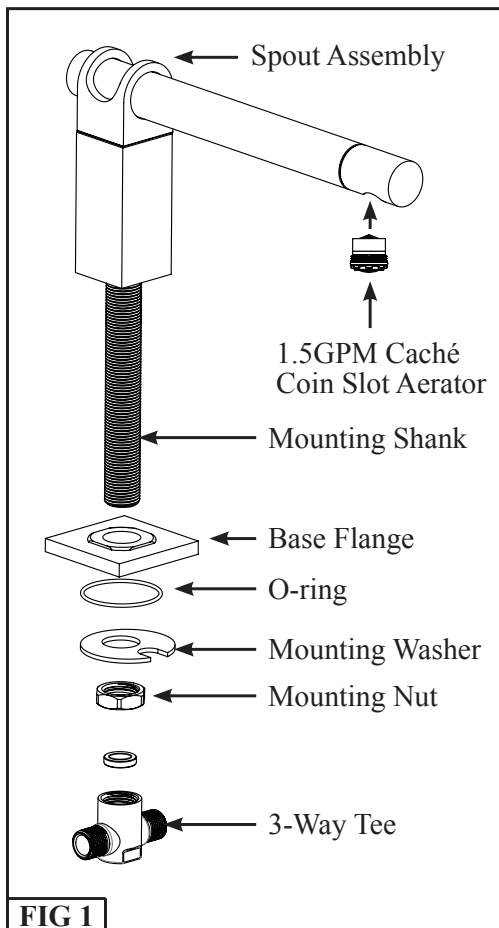

Handle and Valve Installation

Step 1: Install the Valves with the Stem protruding 1-1/2" above the finished deck through the 1-1/4" hole while using the flange, 2 washers and locking nut as your top mounting gear. See **FIG 3**

Note: The 2 washers should sit inside of the round inset in the flange and protrude just above the top of the flange.

Step 2: Install the Strap assembly onto the valve stem and thread the Top Screw onto the Valve. See **FIG 4**.

Note: The Strap assembly should rest on the washers installed in step 1.

Step 3: Install the lever by inserting the lever into the strap and locking the lever into place with the back cap nut. See **FIG 5**.

Note: The Lever Assemblies have 2 Pins that line up with Notches in the Strap to prevent the Lever from rotating.

Step 4: Tighten the Mounting Nut securely under Deck so Valve is firmly in place and does not rotate.

Step 5: Connect Valves to the 3-Way Tee using supplied Hoses. See **FIG 6**.

Step 6: Test system for leaks to complete the installation.

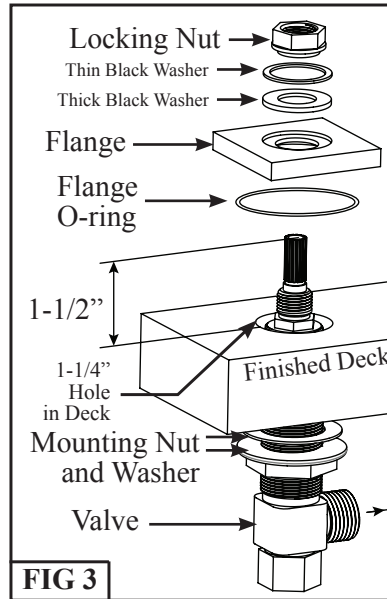

FIG 3

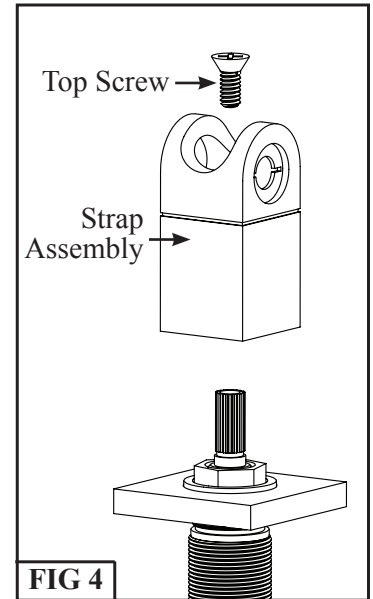

FIG 4

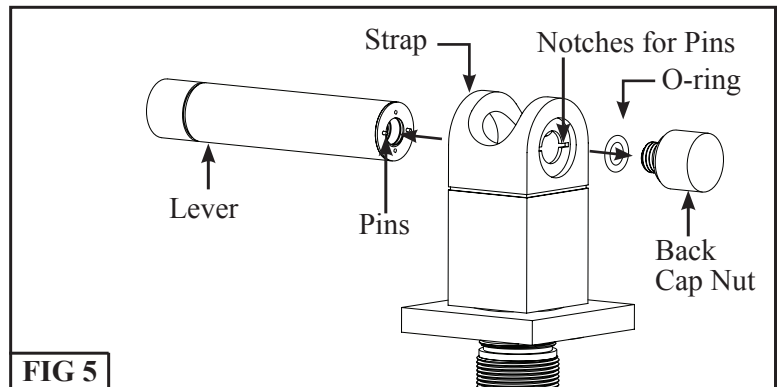

FIG 5

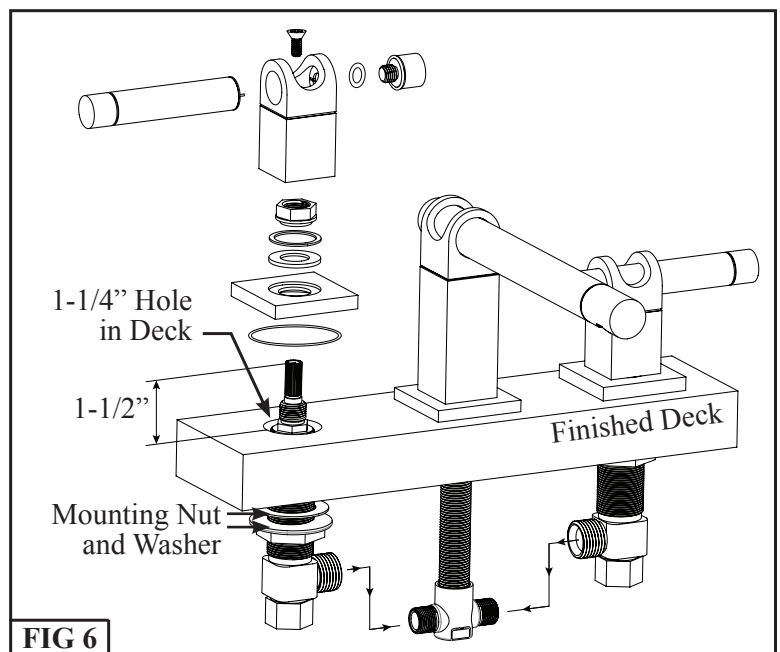

FIG 6